

data sheet

pc_o.flim X

fluorescence (luminescence) lifetime imaging application simplified

resolution
1.0 MPixel

pixel size
5.6 μm x 5.6 μm

interface
USB 3.0



1288
EMVA Standard Compliant

lifetime from
1 ns to 100 μs

high frame rate
45 double frames / s

frequency synthesizer
5 kHz - 40 MHz

unique resolution
1008 x 1008 pixels

enhanced cooling of image sensor
down to - 5 $^{\circ}\text{C}$ (air) / - 20 $^{\circ}\text{C}$ (water)

technical data

image sensor

sensor technology	CMOS
image sensor	proprietary
color type	monochrome
resolution (horizontal x vertical)	1008 pixel x 1008 pixel
pixel size (horizontal x vertical)	5.6 μm x 5.6 μm
sensor size (horizontal x vertical)	5.7 mm x 5.7 mm
sensor diagonal	8.1 mm
shutter type	rolling reset / global exposure
modulation transfer function (theoretical max.)	108.6 lp/mm
fullwell capacity	52,000 e ⁻ (typ.)
readout noise (typ.)	15 e ⁻ rms (typ.)
dynamic range (intra-scene)	1024 :1 (60 dB)
peak quantum efficiency	appr. 39 % @ peak
spectral range	370 nm - 780 nm (FWHM)
dark current	tbd

quantum efficiency

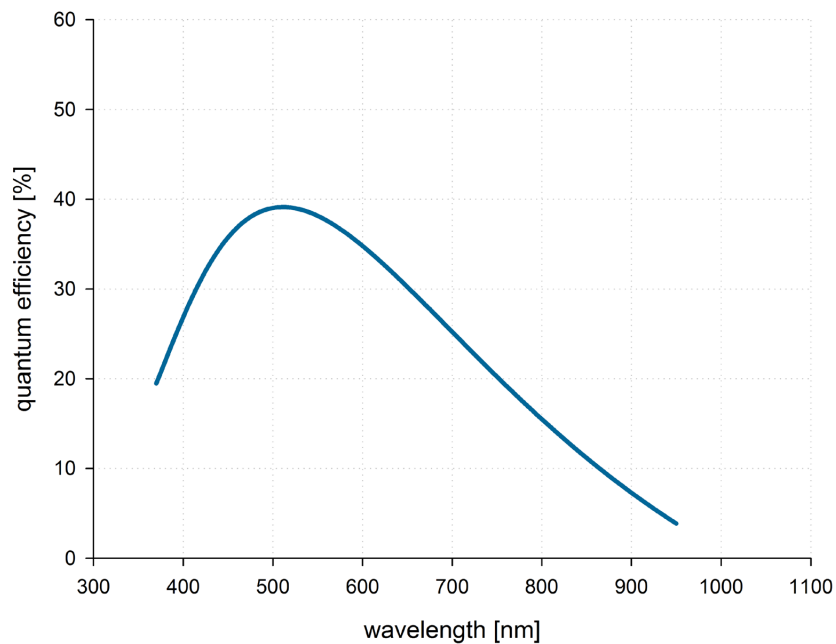

camera	
max. frame rate @ full resolution	45 double frames / s (2 tap readout)
modulation frequency	internal: 5 kHz - 40 MHz external: 500 kHz - 40 MHz
dynamic range A/D	14 bit
conversion factor	3.5 e ⁻ / count
modulation signal shape	sinusoidal / rectangular
region of interest (ROI)	steps of 16x1 pixel
non-linearity	< 1 %
dark signal non-uniformity (DSNU)	56 e ⁻ rms
photo response non-uniformity (PRNU)	0.8 %
cooling temperature image sensor	-5 °C stabilized
cooling method	adjustable: from - 25 °C to + 20 °C peltier with forced air (fan) and water cooling calibration setpoint: - 5 °C
trigger input signals	exposure start (phase sequence trigger)
trigger output signals	exposure, busy, gate (light enable)
input / output signal interface	SMA connectors
time stamp	in image (1 μs resolution)
data interface	USB 3.0



illustration of the pco.flim X and the pco.flim X laser.

general

power supply	90 - 260 VAC (24 VDC opt.)
power consumption	50 W max.
weight	2.4 kg
dimensions (height x width x length)	95 mm x 90 mm x 109 mm
operating temperature range	+5 °C to +40 °C
operating humidity range (non-condensing)	10 % to 80 % (non-condensing)
storage temperature range	-20 °C to +60 °C
CE / FCC certified	yes

optical interface

direct mounting	7.4 mm ± 10 %
lens mounting	C-Mount
optional lens mounting	F-Mount, TFL-Mount

Configure your optical setup with our **MachVis Lens Selector** online tool.

dimensions

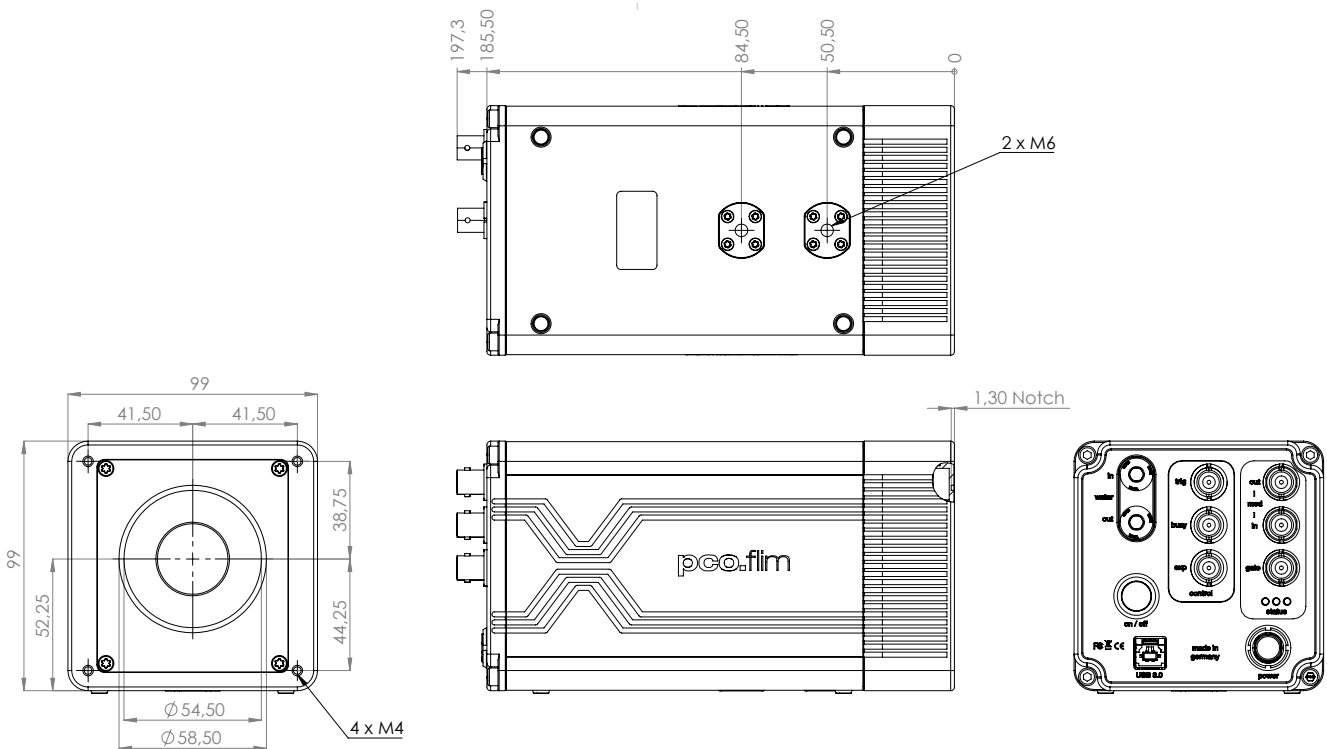

outlines of pco.flim X (all dimensions given in mm).

software

Our main camera control software pco.camware is the first choice to get started with your camera. It enables full control of all camera settings and makes image acquisition and storage very easy. Using different layouts, stiles and features you can customize it exactly to your needs.



You are using a different software:

PCO cameras are also integrated in a variety of software applications. Check our homepage to find a list of all applications that support PCO cameras.



You want to create your own application for the camera:

We offer a wide range of Software Development Kits (SDK) for different programming languages, both for windows and linux. Our pco.sdk, pco.recorder and high-level SDK are designed for C/C++ apps. With pco.python, pco.matlab, pco.labview and pco.java you can control the camera in your C#, python, matlab, labview and java applications, respectively.

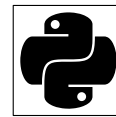
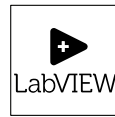
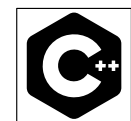
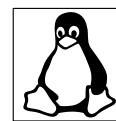
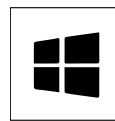

Your use case is in the field of microscopy:

PCO cameras are also integrated in µManager.



areas of application

bright-field microscopy | fluorescence microscopy | digital pathology | lightsheet fluorescence microscopy (LSFM) | selective plane illumination microscopy (SPIM) | Förster resonance energy transfer (FRET) | high-speed bright-field ratio imaging | biochip reading | total internal reflection fluorescence microscopy (TIRF) | industrial quality inspection | inspection | material testing | pressure sensitive paint (PSP) and temperature sensitive paint (TSP) measurements | 2D measurements with optical chemical sensors | digital staining by using the endogenous fluorescence lifetime | solar cell research and quality control (perovskite) | environmental micro plastic detection | improved classification of used wood | use of optical chemical sensors in microfluidics



address: Excelitas PCO GmbH
Donaupark 11
93309 Kelheim, Germany

phone: +49 (0) 9441 2005 0

mail: pco@excelitas.com

web: www.excelitas.com/pco

